

PLANCHE ABDOMINALE

SIMPLE
REF : 616 607 NM

Conforme FD S 52-903
& NF EN 16630



Rondino®

MATÉRIAUX

Pin classe 4
Visserie et boulonnerie inox
Pieds de scellement galvanisés
à chaud et thermolaqués

INSTALLATION

Fixation par pieds à sceller
Surface utile : 5486 x 4150 mm
Espace d'évolution : 21 m²
H.C.L. : 800 mm
Poids : 125 kg

Signalisation (option)

Panneau silhouette et support
Voir fiche panneau gravé

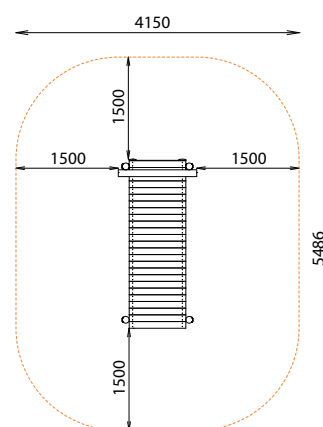
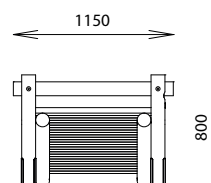
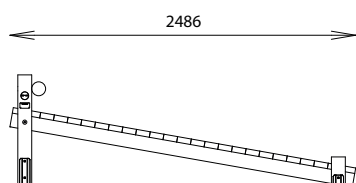
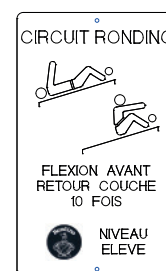

Rondino®

rue de l'industrie
Z.I. du Champ de Mars
42600 SAVIGNEUX

☎ 04 77 96 29 81
✉ info@rondino.fr

www.rondino.fr



MAJ : 13/03/2019