

ESCALIER



Conforme FD S 52-903
& NF EN 16630

Rondino®



Réf 616 191 NM

MATÉRIAUX

Pin classe 4
Barres inox
Visserie et boulonnerie inox
Pieds de scellement galvanisés
à chaud et thermolaqués

INSTALLATION

Fixation par pieds à sceller

Signalisation (option)

Panneau silhouette et support
Voir fiche panneau gravé

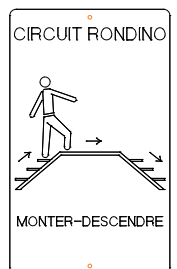

Référence	Dimensions	Hauteur	HCL	Surface utile	Espace d'évolution	Poids	Particularité
616 191 NM	3899 x 1330 mm	1900 mm	800 mm	6899 x 4330 mm	28 m ²	287 Kg	Marches ht 16 cm
616 191-01 NM	4160 x 1330 mm	1400 mm	360 mm	7160 x 4330 mm	30 m ²	275 Kg	Marches ht 6 cm

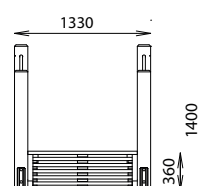
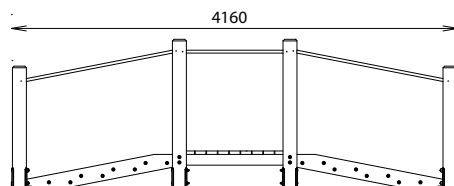
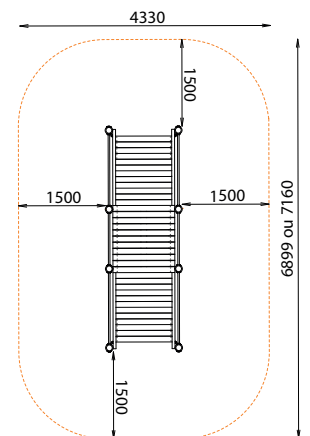
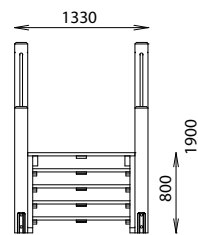
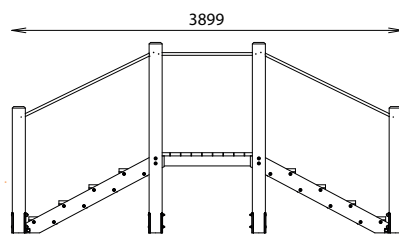

Rondino®

rue de l'industrie
Z.I. du Champ de Mars
42600 SAVIGNEUX
☎ 04 77 96 29 81
✉ info@rondino.fr

www.rondino.fr

