

PASSERELLE

REF : 616 190 NM



Conforme FD S 52-903
& NF EN 16630



MATÉRIAUX

Pin classe 4
Barres inox
Visserie et boulonnerie inox
Pieds de scellement galvanisés
à chaud et thermolaqués

INSTALLATION

Fixation par pieds à sceller
Surface utile : 7130 x 4339 mm
Espace d'évolution : 29 m²
H.C.L. : 277 mm
Poids : 271 kg

Signalisation (option)

Panneau silhouette et support
Voir fiche panneau gravé

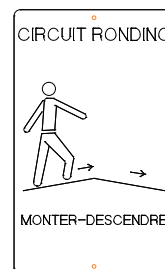

Rondino®

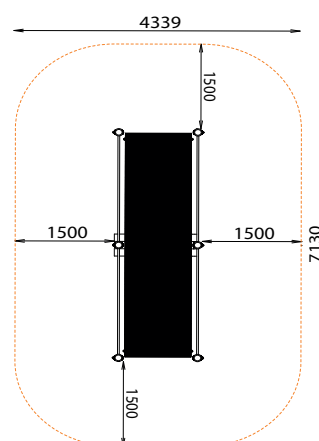
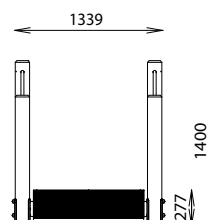
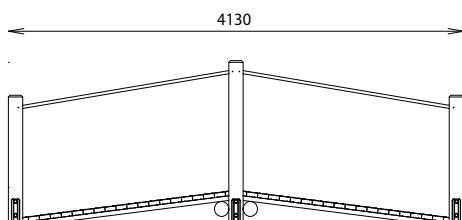

Rondino®

rue de l'industrie
Z.I. du Champ de Mars
42600 SAVIGNEUX

☎ 04 77 96 29 81

✉ info@rondino.fr

www.rondino.fr



MAJ : 12/03/2019