

BURON

REF : 603 210-01

2-12
ans

Rondino®

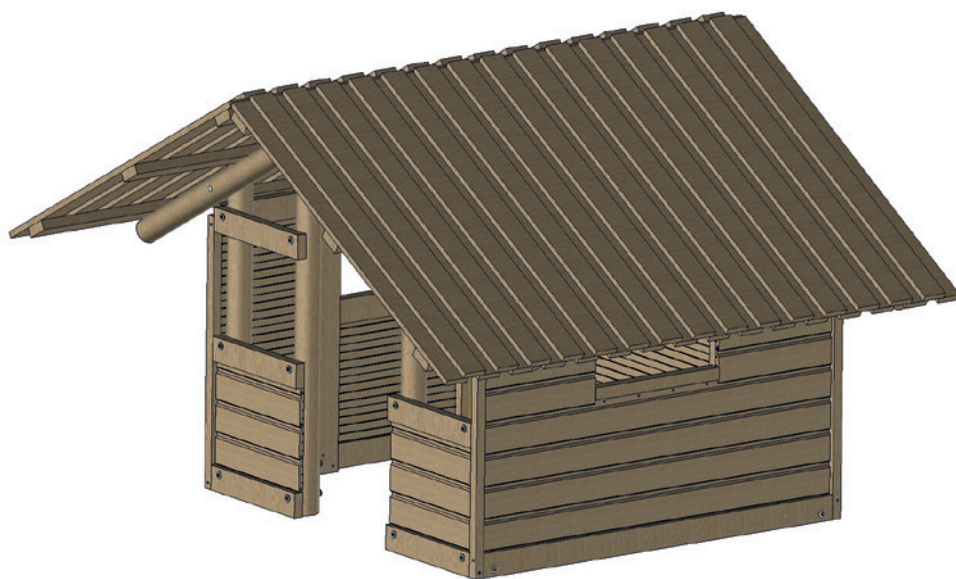

DESSCRIPTIF

Longueur : 2906 mm
Largeur : 2500 mm
Hauteur : 1853 mm

MATÉRIAUX

Pin classe 4

Options :

Banc 603 215

INSTALLATION

Fixation par pattes de scellement
Surface utile : 4780 x 4780 mm
Zone d'impact : 21,00 m²
H.C.L. : 0 mm
Poids : 450 kg

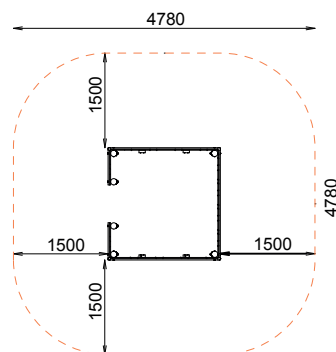
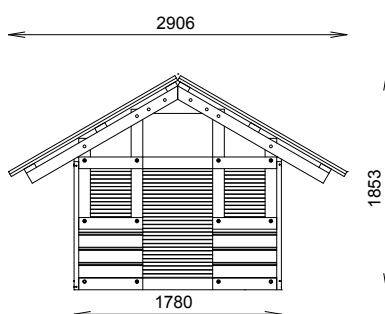
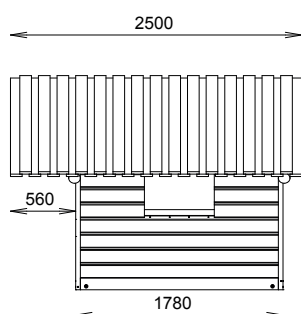

Rondino®

rue de l'industrie
Z.I. du Champ de Mars
42600 SAVIGNEUX

☎ 04 77 96 29 81

✉ info@rondino.fr

www.rondino.fr



MAJ : 28/01/2019